

25 TONNE CHASER BIN

CHASER BIN GRANMAX3125 E

FEATURES

- **Optimal Unloading Tube Position:** The unloading tube is uniquely angled for superior grain discharge, enhancing both speed and efficiency. This feature boosts discharge performance while minimising fuel consumption
- **Improved Discharge Visibility:** With excellent visibility of the discharge spout, operators can easily monitor and precisely guide grain into the hopper, ensuring seamless and efficient transfer
- **Sliding Bottom Doors and Side Access Hatches:** Designed to streamline the unloading process while allowing easy cleaning access, reducing downtime and maintenance efforts.
- **Additional Features:** Easy wind tarp, tool box for convenient storage, integrated clearance lights, anti-slip folding ladder, rear tow hitch and front panels with wide windows
- Electric scales and pivoting spout (Optional)

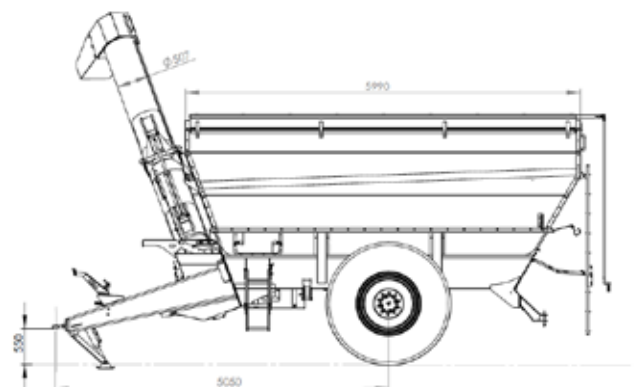
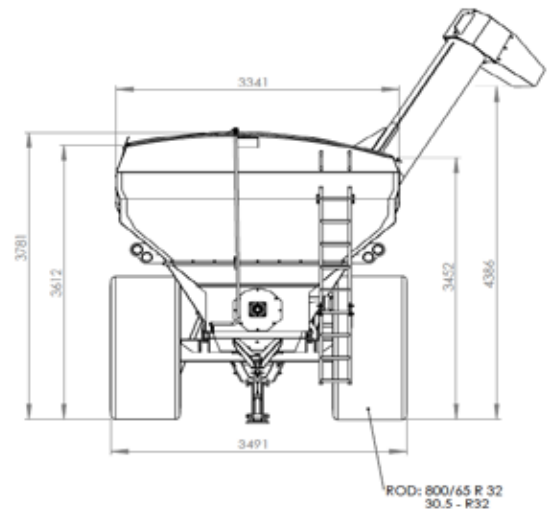

TECHNICAL SPECIFICATIONS

Maximum loading capacity (kg)	25,000
Capacity (L)	32,000
Discharge performance (kg/min)	12,000
Unloading tube diameter (mm)	507
Power required (HP)	160
Gearbox (rpm)	540 / (1000 optional)
Overall Width (mm)	3,341
Bin Height	3,781
Ground to Spout Height	4,386
Bin Length	5,990
Chassis length	5,050
Tyre width (mm) may vary acc to tyre	3,491